

# STRONGHOLD®

## Model SH1752-14

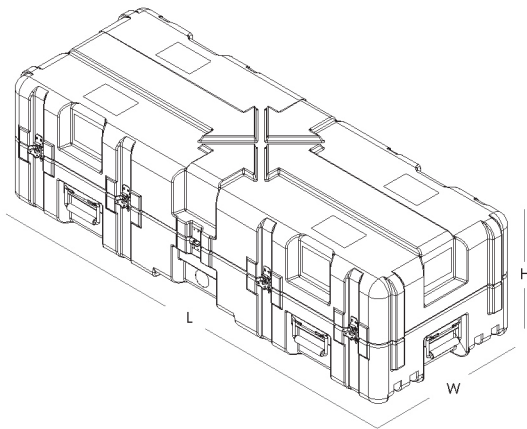

**GUARANTEED  
FOR LIFE**



### SH1752-14 Specifications

|                        |                             |
|------------------------|-----------------------------|
| Interior Dimensions    | 17.1" W x 52.3" L x 14.0" H |
| Exterior Dimensions    | 20.1" W x 56.7" L x 16.3" H |
| Lid Inner Depth        | 7.0"                        |
| Bottom Inner Depth     | 7.0"                        |
| Approx. Weight (empty) | 39.2 lbs                    |
| Material               | Polyethylene                |
| Minimum Temperature    | -40°F (-40°C)               |
| Maximum Temperature    | 160°F (71.1°C)              |

### Standard Features

- Rotationally molded, double-walled construction
- Watertight, airtight, dustproof
- Interlocking stackable design
- Recessed, heavy-duty stainless steel hardware
- Tongue & groove construction with gasket
- Spring-loaded bail handles

### Certifications (capable of manufacturing to)

- MIL-STD-3010 Test Procedures for Packaging Materials and Containers
- FED-STD-101 Test Procedure for Packaging Material
- ATA Specification 300, Category 1
- ASTM D4169
- IP67 – IEC Standard 60529
- MIL-STD 810
- ASTM D999 – Vibration
- ASTM D6179
- ASTM D5276
- STANAG 4280/AEPP-3 Standard Packaging Test Procedures
- ISTA Test Procedure 1A

### Custom Options\*

- Custom foam
- Thermoformed inserts
- Shock mounts
- Literature pockets
- Mounting flanges & brackets
- Automatic pressure relief valve
- Custom colors
- Hinged compartments
- Case wall cutouts
- Name plates
- Mold-in graphics
- Stencil marking
- Removable lid
- Bail handle & wheels
- Removable caster wheels

\*Contact Gemstar for details and pricing



800-533-3631 | [GemstarCases.com](http://GemstarCases.com)

**GEMSTAR**   
CUSTOM HARD CASES