

STRONGHOLD®

Model SH2542-20

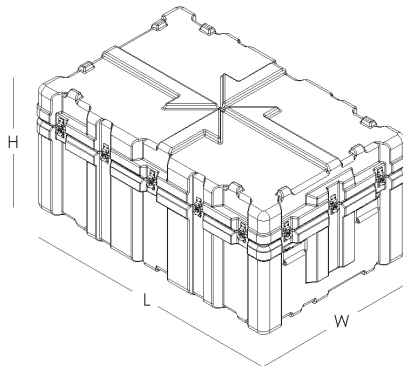

**GUARANTEED
FOR LIFE**



SH2542-20 Specifications

| | |
|------------------------|------------------------------|
| Interior Dimensions | 25.8" W x 42.8" L x 20.63" H |
| Exterior Dimensions | 29.7" W x 46.7" L x 22.9" H |
| Lid Inner Depth | 5.3" |
| Bottom Inner Depth | 15.4" |
| Approx. Weight (empty) | 53.5 lbs |
| Material | Polyethylene |
| Minimum Temperature | -40°F (-40°C) |
| Maximum Temperature | 160°F (71.1°C) |

Standard Features

- Rotationally molded, double-walled construction
- Watertight, airtight, dustproof
- Interlocking stackable design
- Recessed, heavy-duty stainless steel hardware
- Tongue & groove construction with gasket
- Spring-loaded bail handles

Certifications (capable of manufacturing to)

- MIL-STD-3010 Test Procedures for Packaging Materials and Containers
- FED-STD-101 Test Procedure for Packaging Material
- ATA Specification 300, Category 1
- ASTM D4169
- IP67 – IEC Standard 60529
- MIL-STD 810
- ASTM D999 – Vibration
- ASTM D6179
- ASTM D5276
- STANAG 4280/AEPP-3 Standard Packaging Test Procedures
- ISTA Test Procedure 1A

Custom Options*

- Fire retardant resin and inserts
- Custom foam
- Thermoformed inserts
- Shock mounts
- Literature pockets
- Mounting flanges & brackets
- Automatic pressure relief valve
- Custom colors
- Hinged compartments
- Case wall cutouts
- Name plates
- Mold-in graphics
- Stencil marking
- Removable lid
- Reverse application
- Removable caster wheels

*Contact Gemstar for details and pricing



800-533-3631 | GemstarCases.com

GEMSTAR 
CUSTOM HARD CASES