



SENTINEL[®] Cases from Gemstar[®] are injection-molded cases engineered to deliver the ultimate protection for your most valuable assets—for sleek, lightweight protection that can stand up to any demand, choose SENTINEL.

Standard Features

- Injection molded construction
- Watertight, airtight, dustproof
- Automatic pressure relief valve
- Two molded-in padlock brackets
- EPDM gasket
- Military Grade Certification
- Stainless steel hardware
- Easy-open latches

Standard and Custom Options

- Offering a robust selection of custom features, colors, and sizes. For more information visit Gemstarmfg.com, or contact your local Distributor or Sales Manager.

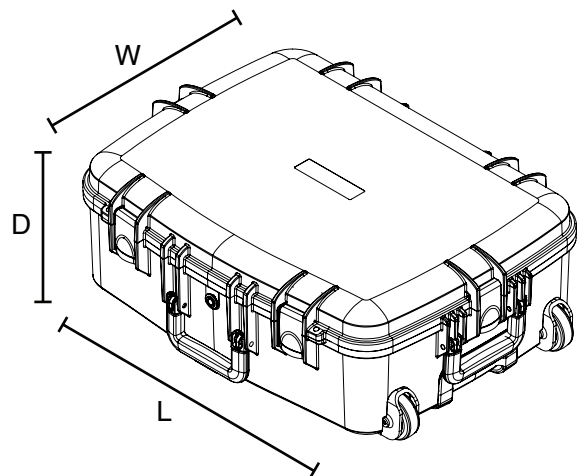

Nominal INT Dimension	24.3"L x 18.1"W x 8.1"D 617L x 460W x 206D mm
-----------------------	--

Base Depth	6.0" 152 mm
------------	----------------

Lid Depth	2.0" 51 mm
-----------	---------------

Nominal EXT Dimension	27.4"L x 20.7"W x 9.6"D 696L x 526W x 244D mm
-----------------------	--

Approx. Weight	17.4 lbs 7.9 kg
----------------	--------------------

Features	<ul style="list-style-type: none"> • Overmolded handle • Wheels • Pull handle • Easy-open latches (4)
----------	---