



**SENTINEL<sup>®</sup> Cases from Gemstar<sup>®</sup>** are injection-molded cases engineered to deliver the ultimate protection for your most valuable assets—for sleek, lightweight protection that can stand up to any demand, choose SENTINEL.

**Standard Features**

- Injection molded construction
- Watertight, airtight, dustproof
- Automatic pressure relief valve
- Two molded-in padlock brackets
- EPDM gasket
- Military Grade Certification
- Stainless steel hardware
- Easy-open latches

**Standard and Custom Options**

• Offering a robust selection of custom features, colors, and sizes. For more information visit [Gemstarmfg.com](http://Gemstarmfg.com), or contact your local Distributor or Sales Manager.

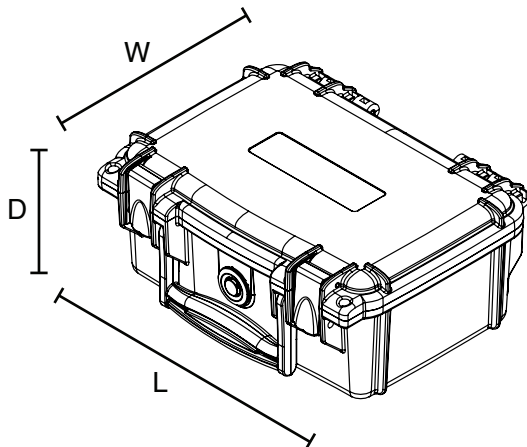

|                       |   |
|-----------------------|---|
| Nominal INT Dimension | 7.7"L x 5.0"W x 3.3"D<br>196L x 127W x 84D mm |
| Base Depth            | 2.8"<br>71 mm                                 |
| Lid Depth             | 0.5"<br>13 mm                                 |
| Nominal EXT Dimension | 8.7"L x 6.8"W x 3.8"D<br>221L x 173W x 97D mm |
| Approx. Weight        | 1.2 lbs<br>0.5 kg                             |
| Features              | • Easy-open latches (2)                       |