



SENTINEL[®] Cases from Gemstar[®] are injection-molded cases engineered to deliver the ultimate protection for your most valuable assets—for sleek, lightweight protection that can stand up to any demand, choose SENTINEL.

Standard Features

- Injection molded construction
- Watertight, airtight, dustproof
- Automatic pressure relief valve
- Two molded-in padlock brackets
- EPDM gasket
- Military Grade Certification
- Stainless steel hardware
- Easy-open latches

Standard and Custom Options

- Offering a robust selection of custom features, colors, and sizes. For more information visit **Gemstarmfg.com**, or contact your local Distributor or Sales Manager.

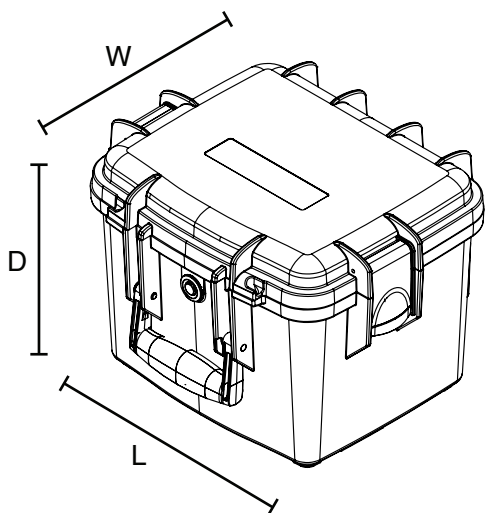

Nominal INT Dimension	10.2"L x 8.3"W x 8.3"D 259L x 211W x 211D mm
Base Depth	7.0" 178 mm
Lid Depth	1.3" 33 mm
Nominal EXT Dimension	12.6"L x 10.4"W x 8.8"D 320L x 264W x 224D mm
Approx. Weight	4.1 lbs 1.9 kg
Features	<ul style="list-style-type: none"> • Overmolded handle • Easy-open latches (2)